

# SiPass® integrated

ACC-AP Door Controller

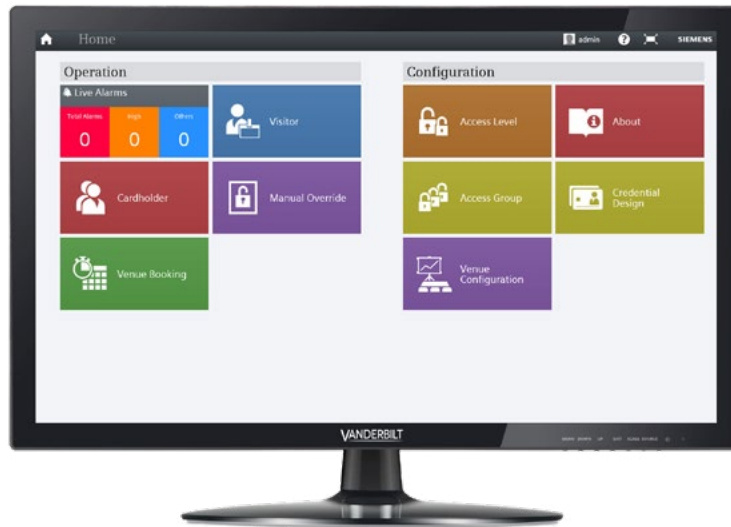

## Key Features include:

- ✓ RS485 connectivity for OSDP readers and FLN devices
- ✓ Flat system architecture
- ✓ Flexible configuration options
- ✓ Auto device discovery

The IP-based ACC-AP door controller offers the latest technology with flexible configuration options. It helps in reduction of overall cost for installation and maintenance; and enables strong autonomous operations of field equipment through secure peer to peer communications.

The controller is capable of controlling up to two doors, supporting FLN devices and hosting of units such as the 8IO, OPM and IPM, while enabling standard features like distributed intelligence, IP addressing of doors, state-of-the art technology and modern design. The ACC-AP controller is connected to an Internet/Intranet network which allows for communication with the SiPass system, and can be configured through the Components dialog in SiPass integrated Configuration Client.

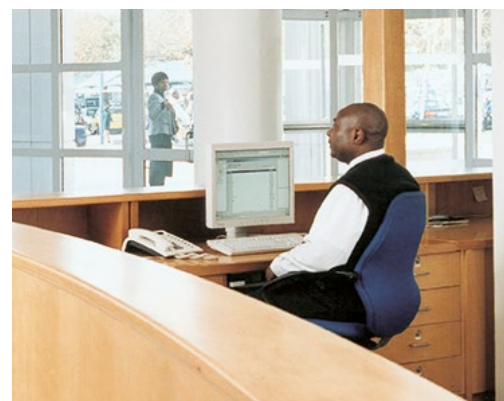
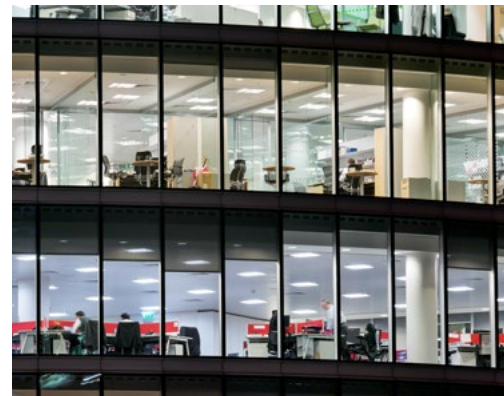

# SiPass® integrated

ACC-AP Door Controller

## Features:

- ✓ 2 OSDP Readers: Controller for one or 2 doors (depending on configuration)
- ✓ 4 Monitored or Unmonitored Inputs
- ✓ 2 Relay Outputs
- ✓ 4 Open-collector Outputs
- ✓ 1 general-purpose FLN bus to connect to IPM, OPM and 8IO devices
- ✓ Capacity for 500,000 users
- ✓ Maximum 5 cards per user
- ✓ Large offline event buffer with up to 200,000 events
- ✓ Anti-passback
- ✓ Linux O/S

**Note:** Only Input/Output devices are supported. No RIM device support available. Inputs and outputs when not as-signed to door can be freely used.

## Benefits:

- ✓ The ACC-AP Door Controller supports structured cabling to the door that helps in utilising existing cabling runs to save costs.
- ✓ Support for up to 750 Controllers (planned for expansion in further market packages), gives you the assurance of flexibility in present and easy expandability in future.
- ✓ The "OSDP V2 Encryption for Readers" is the latest standard in reader communication, while the "AES 128 Bit Encryption between Server to Controller" offers a high-level security at all times.



# SiPass® integrated

ACC-AP Door Controller

## SiPass integrated Hardware Topology with ACC-AP Door Controller:

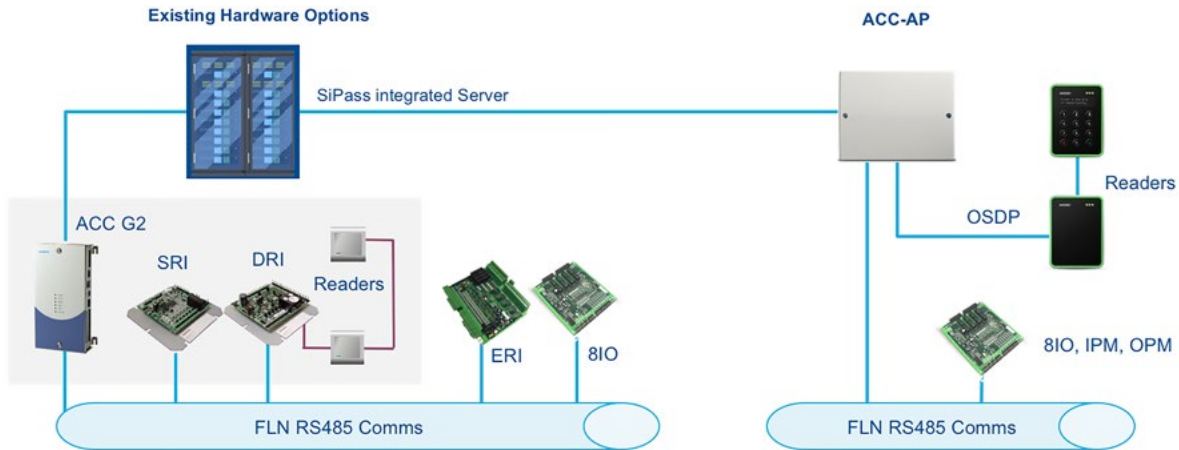

### Technical Data:

Reader Connections	Reader connection via OSDP V1 or V2 encrypted
Mounting	There must be a minimum of 10 mm free area around the housing to de-mount the lid.
Tamper Function	There are two types of tamper switches: <ul style="list-style-type: none"> <li>• Opening the lid</li> <li>• Removing unit from the wall</li> </ul>
Power Supply	The power supply - 12 - 24V DC, can be either a central source (battery supported) or a local PSU
Battery	The supplied "CR2032" battery keeps the Audit Trail data intact for about 30 days during any power fail.

### Technical Data:

Part Number	Type	Description
V54502-C160-A100	ACC-AP	ACC-AP SiPass integrated IP Door Controller
V54502-C162-A100	ACC-APM-1220	ACC-APM-1220 SiPass IP Controller 12V 2A PSU
V54502-C163-A100	ACC-APM-2420	ACC-APM-2420 SiPass IP Controller 24V 2A PSU

**VANDERBILT**

[vanderbiltindustries.com](http://vanderbiltindustries.com)

📞 @VanderbiltInd

📍 Vanderbilt Industries

**Vanderbilt International Ltd.**

Clonshaugh Business and Technology Park  
Clonshaugh, Dublin D17 KV 84, Ireland

☎ +353 1 437 2560